

东莞市讴驰电子科技有限公司

Dongguan Ouchi Electronic Technology Co., Ltd

产 品 规 格 书

Product specification

客户名 Customer Name:	
产品名 Product Name:	10~16S Relay display BMS
产品型号 Product model:	QJ-X16S-1R/2R
版本 Edition:	2.2
日期 Date	2023/07/08

1 产品描述 Product description

QJ-X16S 是针对 10~16 串电池组而设计的智能 BMS 方案，适用于三元、铁锂电池，该产品采用专为储能市场开发，具有较高的电压平衡功能，可通过显示屏查看电池电压和调整参数，直流继电器用于控制电池放电和充电，可承受较高的输出电流。

新品亮点：可以通过不同接线方式，实现一款 BMS 兼容串数范围内电池。（三元：10S-14S;铁锂：12S-16S）

QJ-X16S is a simple intelligent BMS solution designed for 10-16 string battery packs, suitable for ternary and iron lithium batteries. This product is specially developed for the energy storage market and has high voltage balancing function. The battery voltage can be viewed and parameters can be adjusted through the display screen. DC relays are used to control battery discharge and charging, and can withstand high output currents.

The high-voltage DC relay is used to control battery discharge and charging and can withstand high output current. (Li-ion: 10S-14S;Lifepo4: 12S-16S)

2 产品信息 Product information



Size: 124*114*22mm

3 产品参数 Product parameter

项目 List		参数 Parameter
型号 Model	QJ-X16S-1R/2R	10S~16S Split type BMS
电芯类型/串数兼容 Cell type/string compatibility		三元, 铁锂/支持 NMC,LFP / YES
自定义参数 Custom Parameters		LCD 显示屏设置参数 (内置蜂鸣器) LCD setting parameters (built-in buzzer)
工作电压 Working voltage		28~60V
SOC 估算 SOC Estimation		± 5%
工作温度 Operation temperature		-20~80℃
功耗 Power consumption	运行 Run	5W
	休眠 Hibernate	50 μ A
控制单元 Control unit	2x 总电压 0.5A 2x total voltage	1R 相同端口, 2R 不同端口 1R with the same port, 2R with different ports
	平衡 Balance	被动 2A, 主动 3A Passive 2A, Active 3A
	预充 Precharge	IN+1
	开关唤醒 Switch	自复位/LCD 按键 Self reset/LCD button
通信单元 Communication unit	1xTTL	1x 显示屏 1xLCD
采集单元 Acquisition unit	总压 Total voltage	± 100mV FS
	电芯 Cell voltage	0~5V ± 10mV FS
	电流 Electric current	600A 霍尔电流传感器 600A CURRENT SENSOR ± 2%FS
	温度 Temperature	1x 平衡处温控 1xBalance point ± 1℃

4 显示屏通讯 Display communication

4.1 界面展示 Interface display



本产品适用于我公司开发的参数查看和调试设备，支持参数监控、配置修改等功能。
 This product is suitable for parameter viewing and debugging equipment developed by our company, and supports functions such as parameter monitoring and configuration modification.

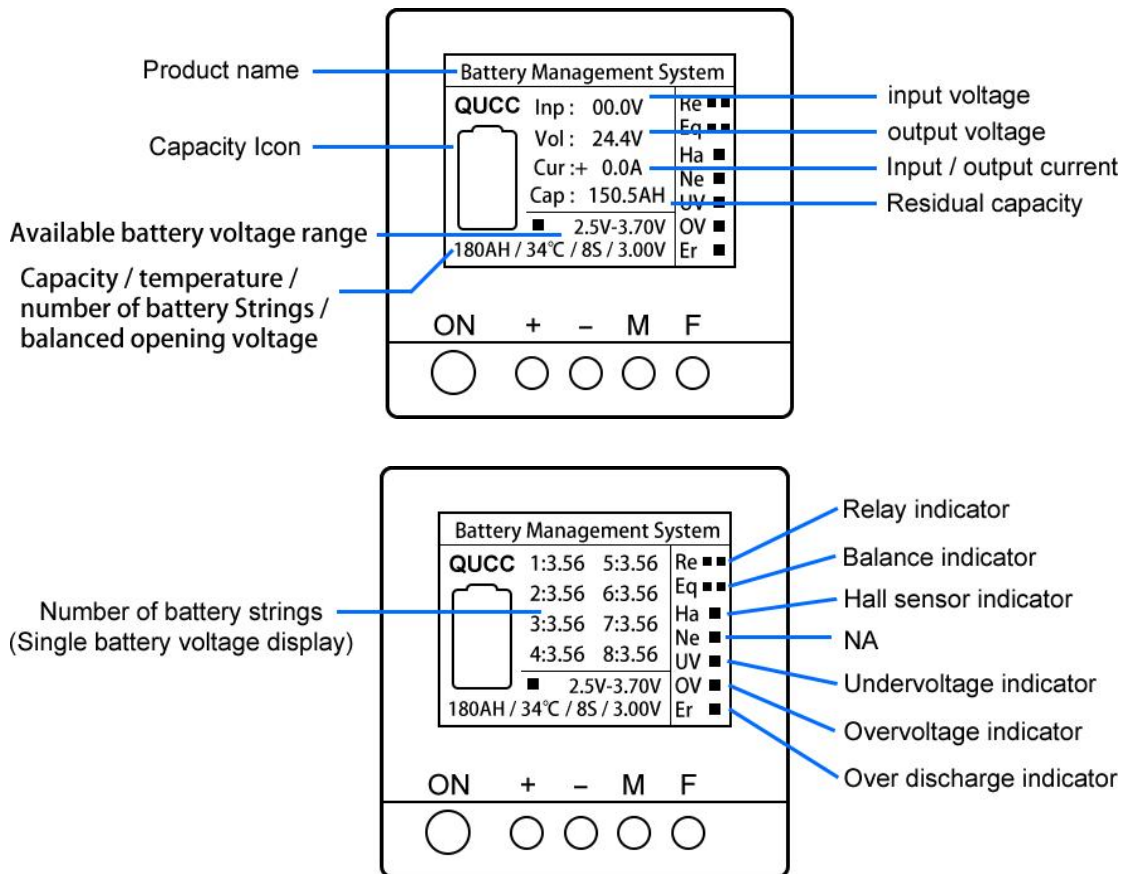

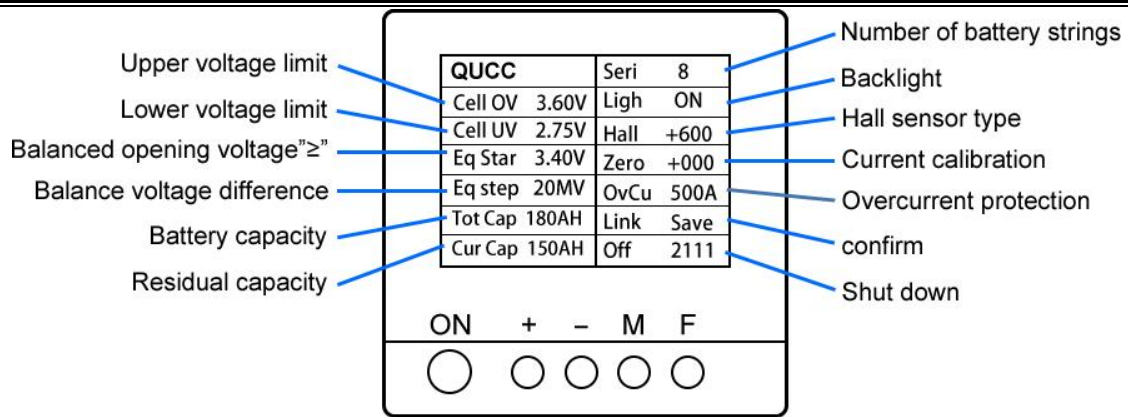

4.2 操作方法 Operation method

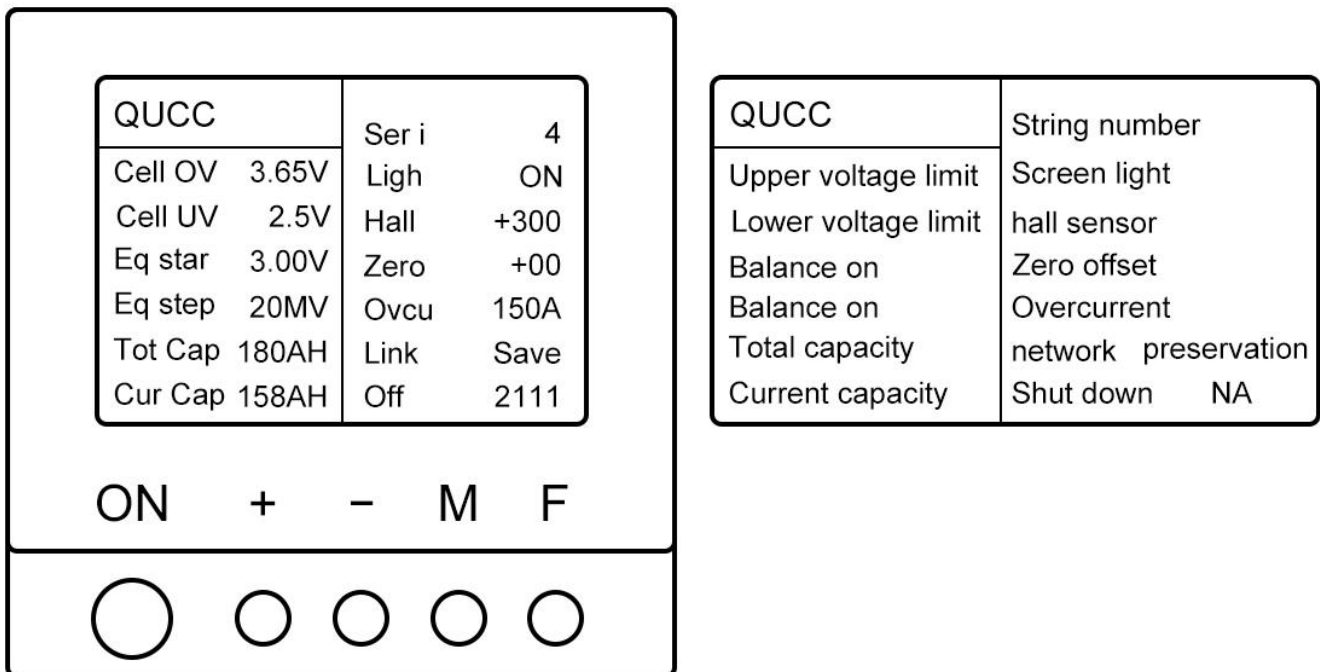

a) 主界面时 Main interface.

ON: 开机 Power on;

F: 长按关机 Long press to shut down;

M: 刷新和切换界面 Refresh and switch the interface.

b) 进入设置 Setting interface

M: 长按进入设置 (切换光标选择) Long press to enter the setting (switch cursor selection).

+ -: 是上调下调 Increase and decrease.

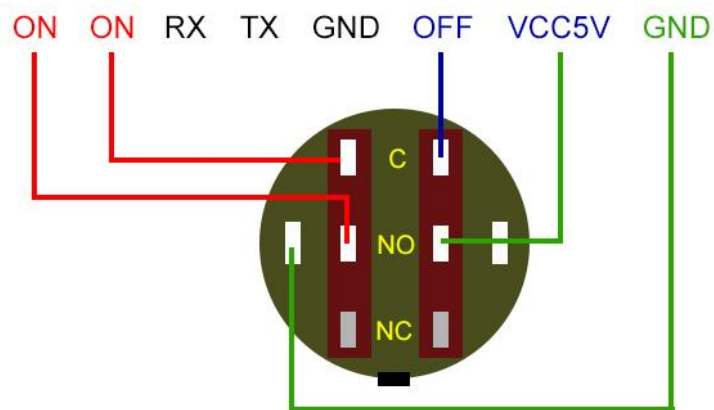

*设置好参数后，可以不用显示屏，使用开关进行开机和关机。

*After setting the parameters, you can use the switch to power on and off without using the display screen.

5 使用及端口定义 Usage and Port Definition

5.1 端口定义 Port definition

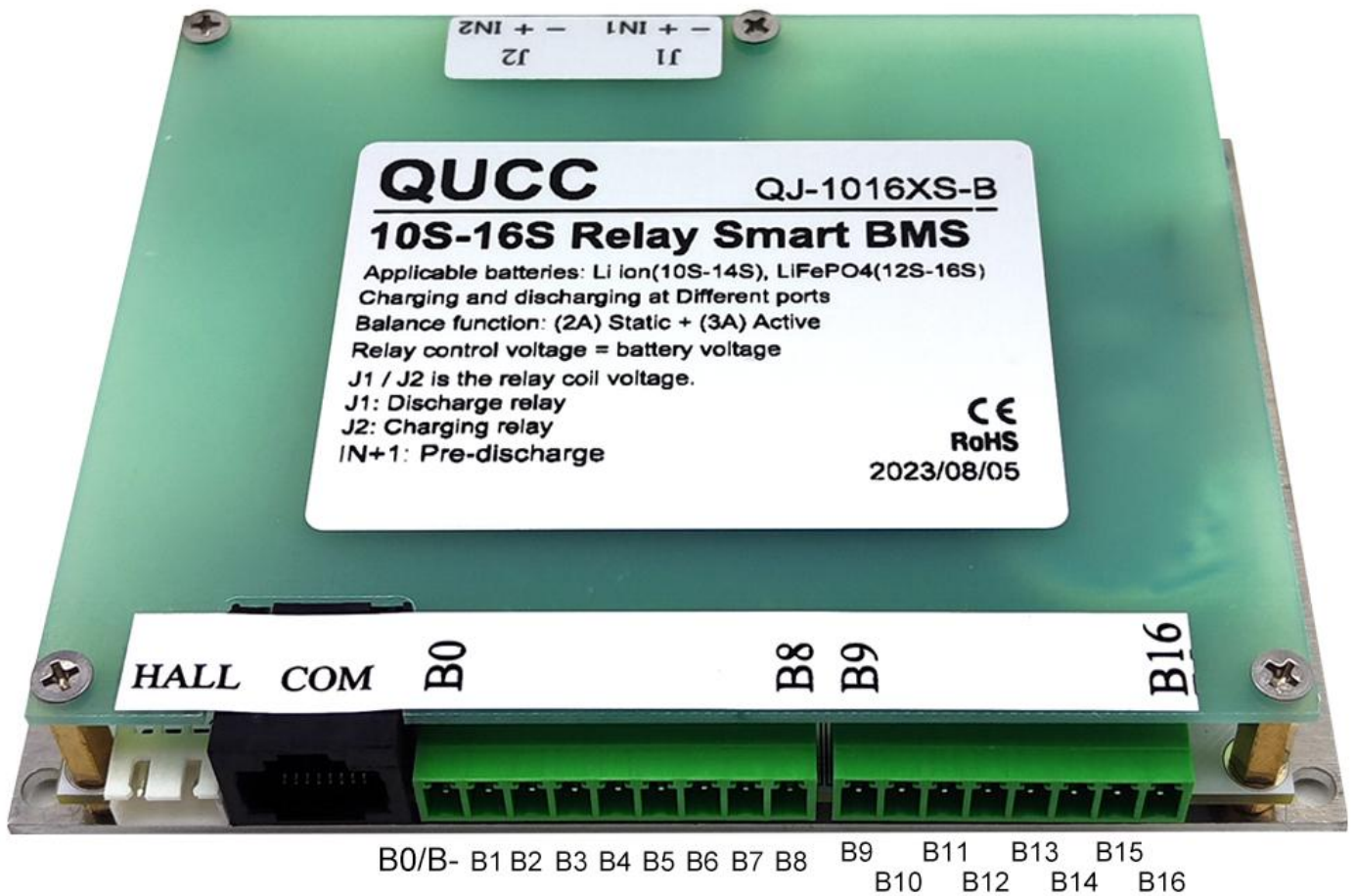

端口定义 Port definition

序	标签 Label	定义 Definition	说明 Remarks
1	HALL	霍尔电流传感器 Hall current sensor	对插即可 Just plug in
2	COM/RJ45	显示屏端口 Display port	对插即可 Just plug in
3	B0-B8	电压采集端口 Voltage acquisition port	电芯 Cell
4	IN1+	电压检测 Voltage detection	充电检测/预充 Charge detection/pre-charge
5	J1+/-	放电继电器 Discharge relay	电池总电压 Total battery voltage(8W)
6	J2+/-	充电继电器 Charging relay	1R 款不接 (1R) not used

IN1+:(1R)款 BMS 是检测充电和继电器接通前给充放电负载内部电容预充。

(2R)款 BMS 是继电器接通前给充放电负载内部电容预充。

Model (1R) BMS is used to pre-charge the internal capacitance of the charge-discharge load before detecting the charging and relay connection.

Model (2R) BMS is to pre-charge the internal capacitance of the charge-discharge load before the relay is connected.

IN2+:of no avail/无效。

5.2 电芯电压采集接线方式 Wiring method for voltage acquisition of battery cells

电压采集端口 Voltage acquisition port						
Strings	10S Battery	12S Battery	13S Battery	14S Battery	15S Battery	16S Battery
B0	B-	B-	B-	B-	B-	B-
B1	B1+	B1+	B1+	B1+	B1+	B1+
B2	B2+	B2+	B2+	B2+	B2+	B2+
B3	B3+	B3+	B3+	B3+	B3+	B3+
B4	B4+	B4+	B4+	B4+	B4+	B4+
B5	B5+	B5+	B5+	B5+	B5+	B5+
B6	B6+	B6+	B6+	B6+	B6+	B6+
B7	B7+	B7+	B7+	B7+	B7+	B7+
B8	B8+	B8+	B8+	B8+	B8+	B8+
B9	B9+	B9+	B9+	B9+	B9+	B9+
B10	B10+	B10+	B10+	B10+	B10+	B10+
B11		B11+	B11+	B11+	B11+	B11+
B12		B12+	B12+	B12+	B12+	B12+
B13			B13+	B13+	B13+	B13+
B14				B14+	B14+	B14+
B15					B15+	B15+
B16	B10+	B12+	B13+	B14+	B15+	B16+

注：请勿反序连接采集端口线缆，防止短路或高压损坏 BMS。

Note: do not connect the acquisition port cables in reverse order to prevent short circuit or high voltage from damaging the BMS.

(Li-ion: 10S-14S;Lifepo4: 12S-16S)

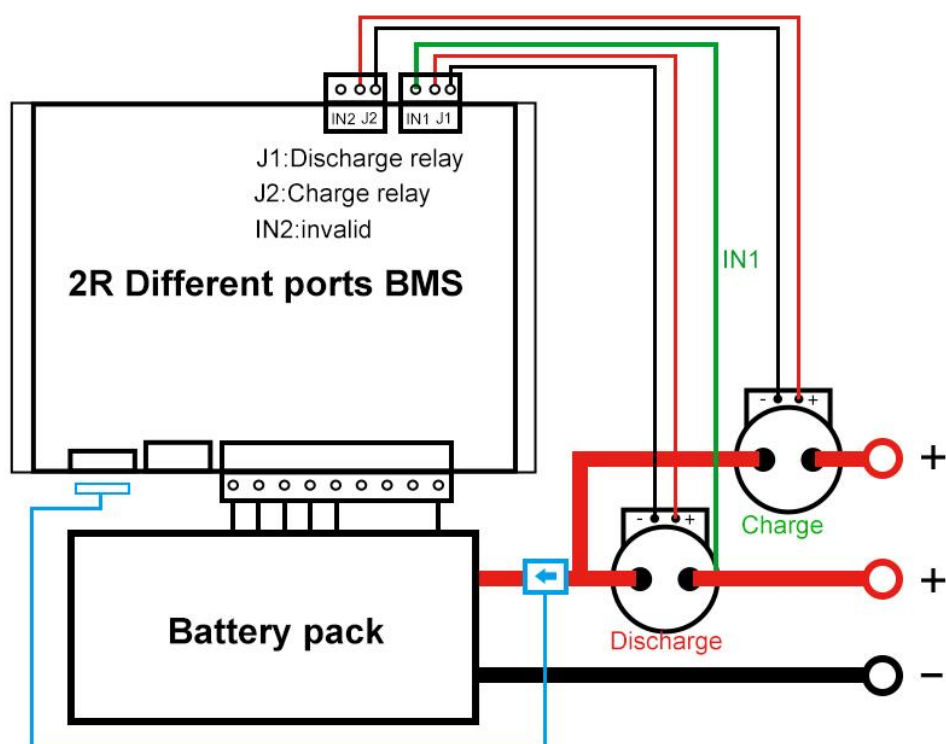
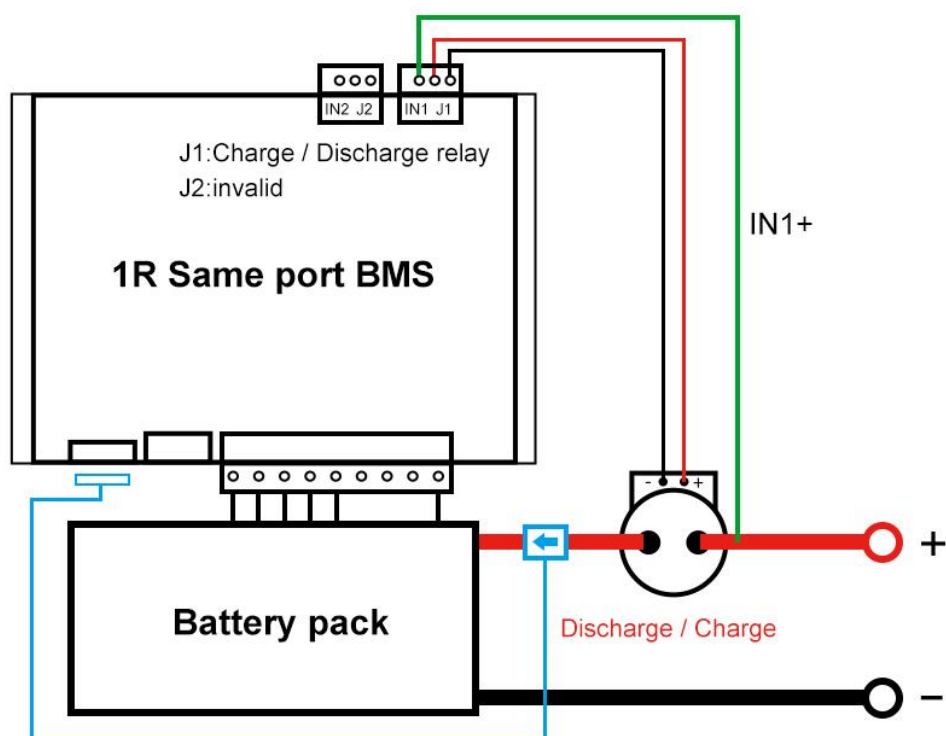

注：请根据型号去使用，不同的 BMS 程序不同，不可混合使用。

Note: please use it according to the model. Different BMS programs are different and cannot be mixed.

6 注意事项 Matters needing attention

- 1 本电池管理系统常规不能串联使用的，高电压会损坏 BMS。
- 2 多个使用本管理系统的电池组并联时，应确保并联之前各电池包的最大压差低于 $\leq 1V$ 。
- 3 本管理系统的短路保护功能适用于多种应用情景，但并不能保证可以在任意条件下短路。
- 4 焊接电池电压采集线时，一定不可有错接或反接，如果确实已接错，这块电路板可能已损坏。
- 5 装配时请勿将 BMS 裸露线缆随意接触到电芯，以免损坏电路板。
- 6 使用中注意线丝、烙铁、焊锡等不要碰到电路板上的元器件，否则有可能损坏本电路板。
- 7 请勿使用高于设计电压充电器和电源对电池组进行充电，高电压会损坏 BMS。
- 8 将电池组和 BMS 组合好以后，初次上电如发现无电压输出或充不进去电，请检查接线和参数是否正确。
- 9 本规格书中的参数、功能和外形仅供参考，以保护板实物为准

- 1 This battery management system cannot be used in series as high voltage can damage the BMS.
- 2 When multiple battery packs using this management system are connected in parallel, it should be ensured that the maximum voltage difference between each battery pack before parallel connection is less than or equal to 1V.
- 3 The short-circuit protection function of this management system is applicable to various application scenarios, but it cannot guarantee that it can short-circuit under any conditions.
- 4 When welding the battery voltage collection line, there must be no misconnection or reverse connection. If it is indeed misconnected, this circuit board may be damaged.
- 5 Do not expose the BMS cables to the battery cells during assembly to avoid damaging the circuit board.
- 6 Be careful not to touch the components on the circuit board with wires, soldering iron, solder, etc. during use, otherwise it may damage the circuit board.
- 7 Do not use chargers and power supplies with voltages higher than the design voltage to charge the battery pack, as high voltage can damage the BMS.
- 8 After combining the battery pack and BMS, if there is no voltage output or charging failure during the initial power on, please check if the wiring and parameters are correct.
- 9 The parameters, functions, and appearance in this specification sheet are for reference only, and the actual protective board shall prevail.

7 产品责任 Product liability

产品使用前，请用户仔细阅读产品规格书，了解产品的使用方法；若出现产品使用方法错误、电路连接不对或采用的输入电源、负载功能参数与产品规格书所标性能参数不符等现象均属使用不当，由使用不当造成产品、负载及周边连接件的损坏，本公司均不承担相关责任。

Before using the product, please carefully read the product specification sheet to understand the usage method of the product; If there are errors in the use of the product, incorrect circuit connections, or discrepancies between the input power supply and load functional parameters used and the performance parameters specified in the product specifications, it is considered improper use. If the product, load, and surrounding connectors are damaged due to improper use, our company will not be held responsible.

该资料的最终解释权归本公司所有。

The final interpretation of this information belongs to our company.